

Specifications

MTL Model NO.	Safety Description			Polarities Available			Typical Applications	Basic Circuit		Max. end-To-end resistance Ω	Vwkg at $1\mu A$ V	Vmax V	Fuse rating mA	Remarks
	V	Ω	mA	+	-	ac		Hazardous	Safe					
7744	10	-	19				Prox sw input, solid state output and line fault detect		-	-	35	50		
	10	-	19											

Dimensions in mm

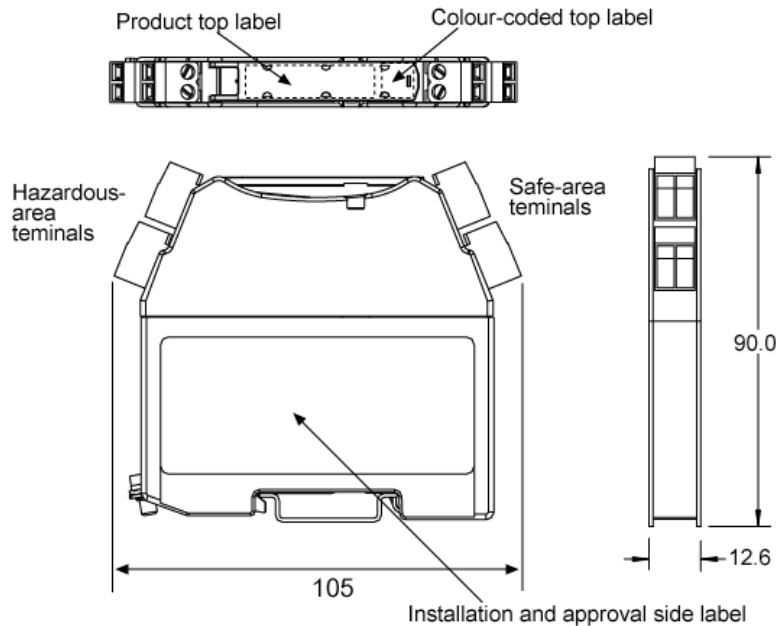

Specification

Safety description

10V 19mA

10V 19mA

Supply voltage

20 to 35V dc with respect to earth

Input characteristics

Output energised if input $>2.1mA (<2k\Omega)$

Output de-energised if input $<1.2mA (<10k\Omega)$

Output characteristics

Operating frequency dc to 2.5kHz

Max off-state voltage 35V

Max off-state leakage $10\mu A$

Max off-state voltage drop $<1.41V @ 50mA$

$<1.22V @ 2mA$

typically $< 1V$

Max on-state current 50mA

Supply current

29mA maximum @ 24V

Ambient temperature and humidity limits

Ambient temperature and humidity limits

$-20^{\circ}C \sim +60^{\circ}C$ continuous working

$-40^{\circ}C \sim +80^{\circ}C$ storage

5~95% RH

Working voltage

0.6V : Leakage current is $10\mu A$

Terminations

Removable terminals accommodate conductors up to $2.5mm^2$ (13AWG), Hazardous-area terminals are identified by blue labels. Removal force $>15N$

Colour coding of barrier label

Grey: Non-polarised

Red : positive polarity

Black : negative polarity

Weight

140g approx

Certificate No. (BASEEFA)

BAS01ATEX7217

REV.	PROJECT NAME:	Cooper Industries Japan K.K. Tokyo, Japan TEL: +81-(0)3-6430-3128 FAX: +81-(0)3-6430-3129	Title		MTL7742 Specification	
REV.	USER NAME :		SIZE	FSCM NO	Drawing No.	rev
REV.	JOB NAME :		DATE:	2009/9/30		SS-MTL7742(E)
	Ref no.:	CHKD	K.T	DRAWN	I.S	SCALE N/A SHEET 1 / 1