

Specifications

MTL Model NO.	Safety Description			Polarities Available			Typical Applications	Basic Circuit		Max. end-To-end resistance Ω	Vwkg at $1\mu A$ V	Vmax V	Fuse rating mA	Remarks
	V	Ω	mA	+	-	ac		Hazardous	Safe					
7787+	28	300	93	└			Transmitters Contoroller outputs, Switches		333	26.6	27.2	50		
	28	diode	-						0.9V+26 Ω	26.6	27.2	50		

Dimensions in mm

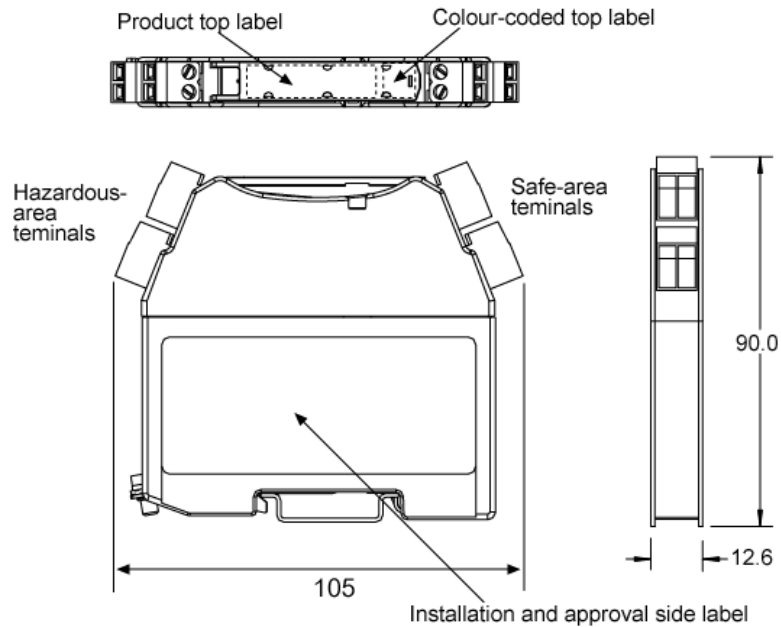

Common Specification

Ambient temperature and humidity limits

Ambient temperature and humidity limits

-20°C~+60°C continuous working

-40°C~+80°C strage

5~95% RH

Working voltage

0.6V : Leakage current is $10\mu A$

Terminations

Removable terminals accommodate conductors up to 2.5mm² (13AWG), Hazardous-area terminals are identified by blue labels. Removal force >15N

Colour coding of barrier label

Grey : Non-polarised

Red : positive polarity

Black : negative polarity

Weight

140g apporox

Certificate No. (BASEEFA)

BAS01ATEX7217

REV.	PROJECT NAME :	Cooper Industries Japan K.K. Tokyo, Japan		Title MTL7787+ Specification					
REV.	USER NAME :	TEL: +81-(0)3-6430-3128 FAX: +81-(0)3-6430-3129		SIZE	FSCM NO	Drawing No.	rev		
REV.	JOB NAME :	DATE:	2009/9/28	SS-MTL7787+(E)					
	Ref no.:	CHKD	K.T	DRAWN	I.S	SCALE	N/A	SHEET	1 / 1